

Type 900X

Miniature I/P, E/P Transducer

Installation, Operation and Maintenance Instructions

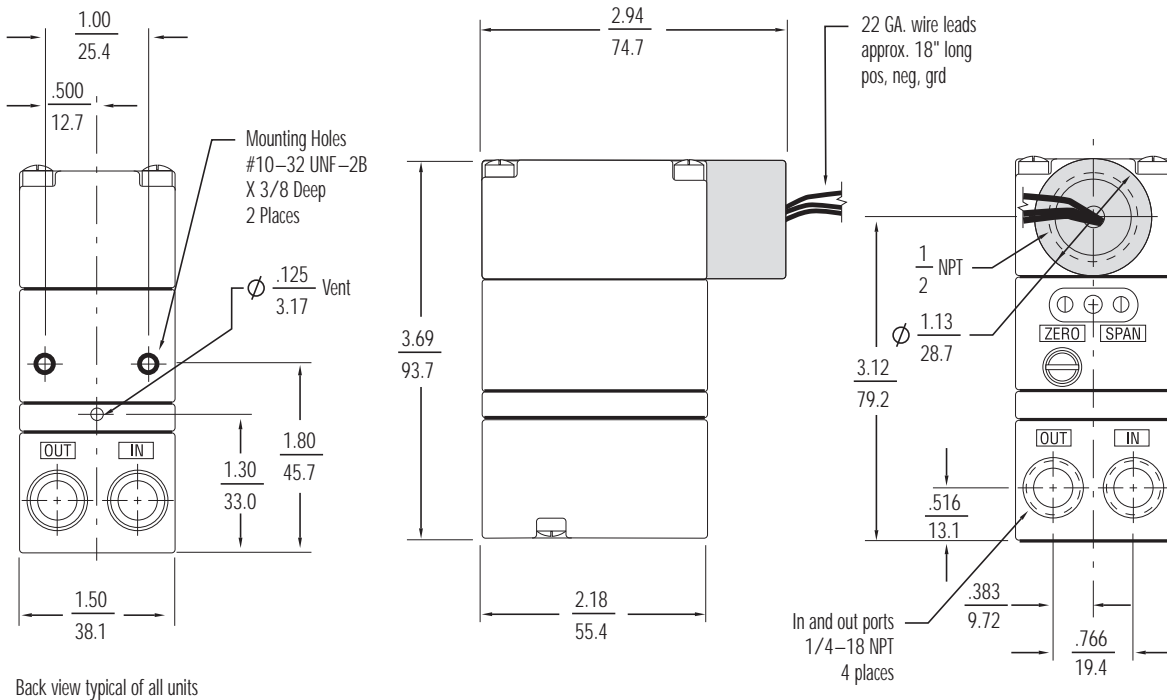

Use this coding system to order

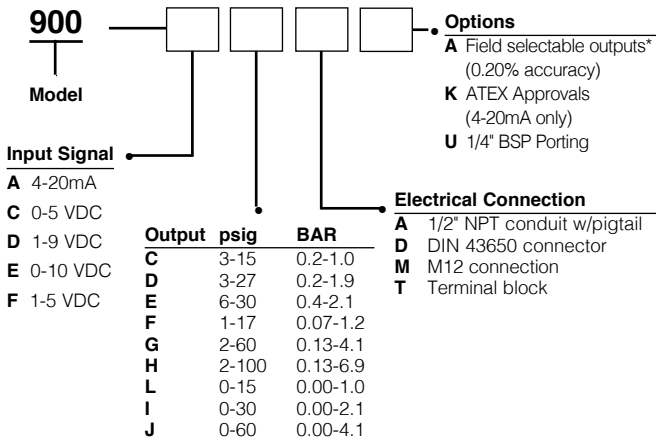

Contents

Section	Description	Page
1.0	Description & Installation	3
2.0	Operation	5
3.0	Maintenance & Repairs	7
4.0	Troubleshooting	8
5.0	Warning	8
6.0	Warranty	8



8 Columbia Drive
 Amherst, NH 03031 USA
 603-886-9400
 Fax: 603-889-1844
 www.controlair.com
 sales@controlair.com



DANGER, WARNING, CAUTION and NOTE statements

- DANGER** Refers to conditions or hazards which could result in serious personal injury or death.
- WARNING** Refers to conditions or hazards which could result in personal injury.
- CAUTION** Refers to conditions or hazards which could result in equipment or property damage.
- NOTE** Alerts you to facts or special instructions.

ALL DANGER, WARNING, AND CAUTION NOTICES MUST BE COMPLIED WITH IN FULL

SPECIFICATIONS

Functional Specifications

	Standard Range					High Output Range			
Inputs	4-20 mA, 0-10VDC, 1-9 VDC, 0-5 VDC, 1-5 VDC								
	Note: Extended periods of electrical input without supply air pressure may damage unit.								
Outputs	1-17	3-15	3-27	6-30	0-15*	0-30*	2-60	2-100	0-60*
psig (BAR)	(0.07-1.2)	(0.2-1.0)	(0.2-1.8)	(0.4-2.0)	(0.0-1.0)	(0.0-2.0)	(0.14-4.0)	(0.14-6.9)	(0.0-4.0)
Supply Pressure									
psig (BAR)	22-60 (1.5-4.0)	20-100 (1.4-6.9)	32-100 (2.2-6.9)	35-100 (2.4-6.9)	25-65 (1.72-4.5)	40-70 (2.75-4.82)	65-100 (4.5-6.9)	105-130 (7.2-9.0)	70-80 (4.82-5.5)
Air Consumption	*Zero-based units have slightly higher air consumption					1.5 scfh (0.04 m3/hr) at mid range typical		4.5 scfh (0.13 m3/hr) at mid range typical	
Flow Capacity						4.5 scfm (7.6 m3/hr) at 25 psig (1.7 BAR) supply		20.0 scfm (34.0 m3/hr) at 130 psig (9.0 BAR) supply	
						12.0 scfm (20.0 m3/hr) at 100 psig (7.0 BAR) supply			
Temperature Limits	Operating: -40° to +158° F (-40° to +70° C) Storage: -40° to +200° F (-40° to +93° C)								
Loop Load, I/P Transducer	9.5 VDC @ 20 mA								
Supply Voltage, E/P Transducer	7-30 VDC, less than 3 mA								
Signal Impedance E/P Transducer	10 Kilohms								

Performance Specifications

Accuracy, Hysteresis and Repeatability	±0.10% of span guaranteed
Deadband	0.02% of span
Position Effect	No measurable effect
Vibration Effect	Less than ±1.0% of span under the following conditions: 5-15Hz @ 0.8 inches constant displacement 15-500Hz @ 10g s
Supply Pressure Effect	No measurable effect
Temperature Effect	±0.045%/F (0.07%/C) of span
Reverse Polarity Effect	No damage occurs from reversal of normal supply current (4-20mA) or from misapplication of up to 60mA
RFI/EMI Effect	See section 1.8

Physical Specifications

Port Sizes	Pneumatic: 1/4" NPT
Media	Clean, dry, oil-free air-filtered to 40 micron
Electrical Connections	Conduit 1/2" NPT, Terminal Block, DIN 43650, M12
Mounting	Wall, panel, 2" pipe, or DIN rail (optional)
Materials	Housing: Chromate-treated aluminum with baked paint, NEMA 4X (IP65) Elastomers: Buna-N Trim: Stainless steel; brass; zinc-plated steel
Weight	13.0 oz. (0.4 kg)

1. DESCRIPTION and INSTALLATION

1.1 Description

- 1.1.1 The ControlAir Type 900 converts a current or voltage input signal to a linearly proportional pneumatic output pressure. This unit utilizes a closed loop pressure feedback system that closely controls output and compensates for vibration, mounting angle, temperature and supply pressure variations. The control mechanism is a piezoceramic actuator. The unique properties of this actuator protect it against moisture and breakage associated with similar competitive technologies.

1.2 Principle of Operation

- 1.2.1 The Type 900 transducer is a force balance device in which the piezo actuator is positioned in relation to a nozzle as the input signal is varied. The application of an electrical signal causes axial movement of the actuator. The actuator moves toward the nozzle and creates back pressure which acts as a pilot pressure to an integral booster relay.

1.3 Mounting

- 1.3.1 Each Type 900 comes with a mounting kit which enables pipe, panel or wall mounting of the unit. An optional mounting kit is available for DIN-rail mountings. The Type 900 may be mounted at any angle.
- 1.3.2 Panel: With access to rear of panel, attach transducer to panel using two 10-32 screws and the two threaded mounting holes on the back of the unit. With no access to the rear of a panel, attach bracket to transducer using two 10-32 holes on the back of the unit and mount bracket to panel using four 10-32 screws (see figure 1).

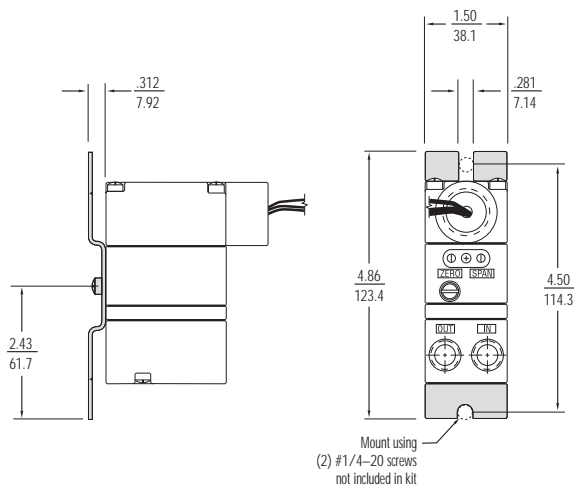

Figure 1 - Standard Panel Mount

- 1.3.3 **In-Line:** Due to its light weight, the Type 900 may be supported by the piping used for supply and output.
- 1.3.4 **1 1/2" Pipe:** Attach bracket to transducer using two 10-32 holes on the back of unit. Place U-bolt around pipe and through bracket. Place nuts on U-bolt and tighten (see figure 2).

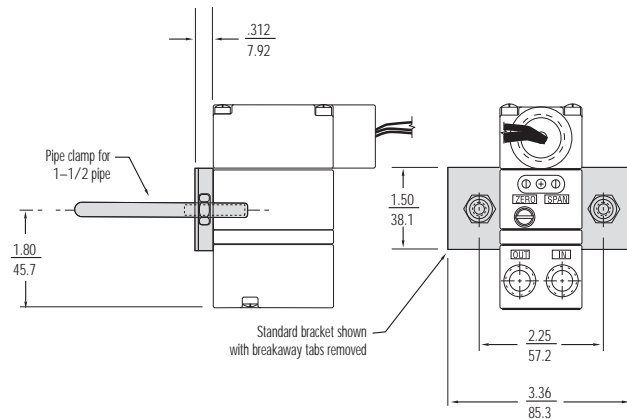
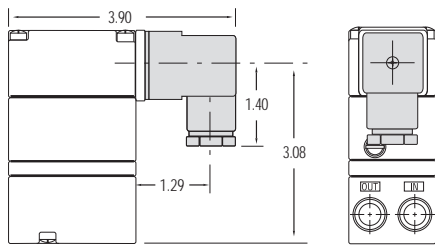
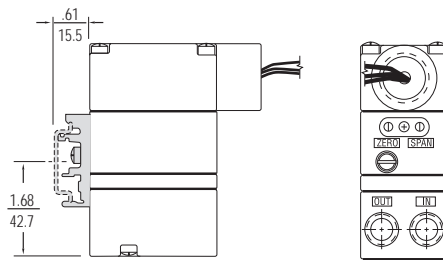

Figure 2 - Standard 1 1/2" Pipe Mount



DIN 43650 Connector



DIN Rail mounting kit 445-766-024

DIN Rail Kit suitable for EN-50035, EN-50045 and EN-50022 Rails

Figure 3

1.4 Pneumatic Connections

- 1.4.1 Clean all pipe lines to remove dirt and scale before installation.
- 1.4.2 Supply air must be filtered to 40 microns and free of moisture and lubricants.
- 1.4.3 The 1/4" NPT inlet and outlet connections are labeled on the body. Plug all unused ports with pipe plugs supplied with the unit. Avoid getting pipe sealant inside the piping or transducer.

WARNING The I/P transducer enclosure contains aluminum and is considered to constitute a potential risk of ignition by impact or friction and must be taken into account during installation.

1.5 Electrical Connections

- 1.5.1 **Conduit Connection (current to pressure)** Electrical connections are made to the red (+) and black (-) leads. The green lead is furnished for case ground (see figure 4).
- 1.5.2 **Conduit Connection (voltage to pressure)** Electrical connections are made to the red (+ supply), black (- return for both supply and signal) and orange (+ signal) leads. The green lead is furnished for case ground. Recommended supply voltage is 7-30 v DC (see figure 5).
- 1.5.3 **DIN Connection (current to pressure)** Electrical connections are made to terminal 1 (+) and 2 (-). The ground symbol is furnished for a case ground (see figure 5).
- 1.5.4 **DIN Connection (voltage to pressure)** Electrical connections are made to terminal 1 (+ signal), 2 (- return for both supply and signal) and 3 (+ supply). The ground symbol is furnished for case ground. Recommended supply voltage is 7-30 v DC (see figure 5).
- 1.5.5 **Terminal Block Connection (current to pressure)** Electrical connections are made to + (positive) and - (return) terminals. The ground symbol is furnished for case ground (see figure 5).
- 1.5.6 **Terminal Block Connection (voltage to pressure)** Electrical connections are made to S (+ power supply), + (+ control signal) and - (return for both supply and signal). The ground symbol is furnished for case ground. Recommended supply voltage is 7-30 v DC (see figure 5).
- 1.5.7 **M12 (M) Electrical Connections** are made to the positive (+) pin 2 and negative (-) pin 1. For direct acting operation connect the positive side of the input signal to the (+) pin 2. Pin 4 is for case ground. Pin 3 is not used. (see figure 6)

CAUTION Do not apply electrical input for extended periods without air pressure being present.

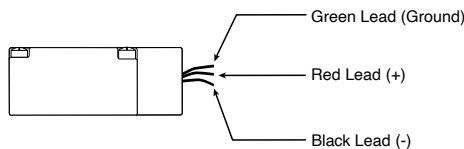

I/P Conduit Connection

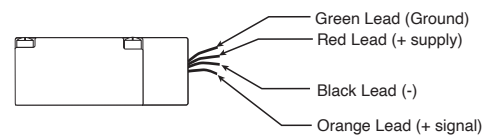

E/P Conduit Connection

Figure 4

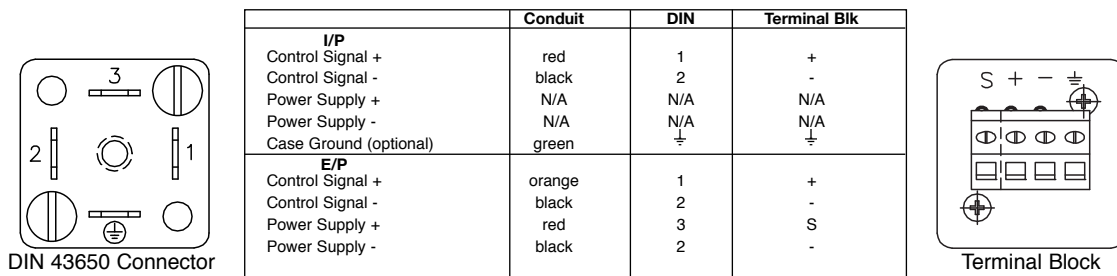

DIN 43650 Connector

Terminal Block

Figure 5

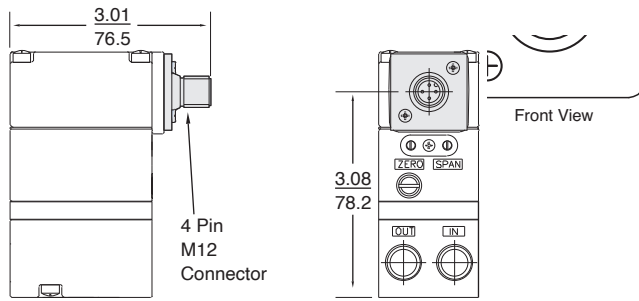

Figure 6 - M12 Connector

	Terminal Blk
I/P	
Control Signal +	Pin 2
Control Signal -	Pin 1
Power Supply +	N/A
Power Supply -	N/A
Case Ground (optional)	Pin 4
E/P	
Control Signal +	Pin 2
Control Signal -	Pin 1
Power Supply +	Pin 3
Power Supply -	Pin 1

1.6 Factory Mutual Research Corporation (FM) & Canadian Standards (CSA) Approvals



Intrinsically Safe (1/2" NPT Conduit)

Class I, II, III, Division 1,
Groups C, D, E, F, & G
Enclosure Nema 4X(IP 65)
Temp. Code T4 Ta = 70° C
Rated 4-20 mA, 30 VDC Max.

Intrinsically Safe (DIN & Terminal)

Class I, Division 1, Groups C & D
Temp. Code T4 Ta = 70° C
Rated 4-20 mA, 30 VDC Max.

Entity Parameters (Conduit)

Ui (Vmax) = 30 VDC Ci = 0 uF
Ii (Imax) = 125 mA Li = 0 mH
Pi = .7 w Max.

Non-Incendive (Conduit, DIN, Terminal)

Class I, Division 2,
Groups A, B, C & D
Temp. Code T4 Ta = 70° C

Suitable for (Conduit only)

Class II & III, Division 2,
Groups F & G
Temp. Code T4 Ta = 70° C

Entity Parameters (DIN & Terminal)

Ui (Vmax) = 30V Ci = .03 uF
Ii (Imax) = 125 mA Li = 0 mH
Pi = 0.70 watts

1.7 ATEX Approvals (option k)

Ex ia IIB T4
Tamb = -40° C to +70° C
FM 08ATEX0048X

Entity Parameters

Ui (Vmax) = 30 VDC Ci = 1 nF
Ii (Imax) = 125 mA Li = 2.2 mH
Pi = .7 W Max.



INSTALLATION DRAWING NO. 431-990-023

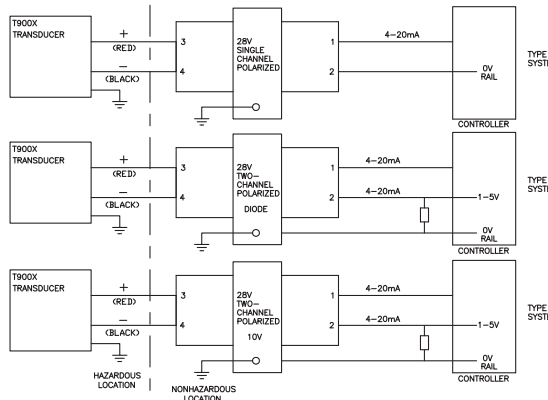
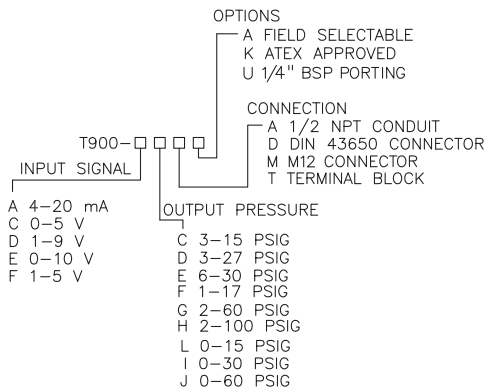

Notes

- (North America) Control equipment connected to the Associated Apparatus must not use or generate more than 250 Vrms or Vdc.
- The IS Barriers or Equipment (Associated Apparatus) must be FM Approved and the configuration of associated Apparatus must be FM Approved and CSA certified under the Entity Concept. The Associated Apparatus may be installed within the Hazardous (Classified) location for which it is approved. The Associated Apparatus and hazardous location loop apparatus manufacturer's control drawings must be followed when installing this equipment. An AEx [ib] Associated Apparatus is suitable only for connection to Class I, Zone 1, Hazardous (Classified) Locations and is not suitable for Class I, Zone 0, or Class I, Division 1 Hazardous (Classified) Locations.
- (ATEX) The IS barriers or other Associated Apparatus shall comply with the ATEX directive 2014/34/EU. Control equipment connected to the Associated Apparatus shall not use or generate more than the marked Um.
- (US) Installation should be in accordance with ANSI/ISA RP12.6 "Installation of Intrinsically Safe Systems for Hazardous (Classified) Locations" and Article 500 of the National Electrical Code (ANSI/NFPA 70). (Canada) Installation should be in accordance with Section 18 of the Canadian Electrical Code. (ATEX) Installations shall comply with EN 60079-14
- (North America) The connection option "A" is suitable for Type 4X installations. All others must be mounted in a suitable enclosure.
- The connection option "A" is suitable for Class I, II, and III, Division 2, Groups A, B, C, D, E, F, and G hazardous (classified) locations. Dust-tight conduit seal must be used when installed in Class II and Class III environments.

The connection options "D" and "T" are suitable for Class I, Division 2, Groups A, B, C, and D hazardous (classified) locations. Transducers to be installed in accordance with the: (US) National Electrical Code(ANSI-NFPA 70) Division 2 hazardous (classified) location wiring techniques. (Canada) Canadian Electrical Code

- The Intrinsic Safety Entity concept allows the interconnection of two FM Approved Intrinsically safe devices with entity parameters not specifically examined in combination as a system when:
 $U_i \text{ or } V_{max} > U_o \text{ or } V_o \text{ or } V_t > 7.2 \text{ volts}$
 $I_i \text{ or } I_{max} > I_o \text{ or } I_{sc} \text{ or } I_t$
 $C_a \text{ or } C_o > C_i + C_{cable}$
 $L_a \text{ or } L_o > L_i + L_{cable}$
 $P_i > P_o$
- No revision to this drawing is permitted without prior FM Approvals notification.
- The Intrinsic Safety Entity concept allows the interconnection of two EC-Type certified devices with entity parameters, not specifically examined in a combination when:
 $U_i > U_o$
 $I_i > I_o$
 $C_a > C_i + C_{cable}$
 $L_a > L_i + L_{cable}$
 $P_i > P_o$
- Because the enclosure is made of aluminum, if it is mounted in an area where the use of category 1G apparatus is required, it must be installed such that even in the event or rare incidents, ignition sources due to impact and friction sparks are excluded.

1.8 EU Declaration of Conformity



We, ControlAir LLC.
8 Columbia Drive
Amherst, NH 03031

Declare that the Type 900X Transducer family to which this declaration applies, comply with these standards:

EN 50082-1:1998
EN 55011:1999
EN 61010-1:1993 including AMD2:1995

Following the provisions of EMC directive 89/336/EEC

EN 60079-0:2006
EN 60079-11:2007

Following the provisions of ATEX directive 2014/34/EU

2. OPERATION

2.1 Calibration

- 2.1.1 All units are shipped from the factory calibrated, direct acting.
- 2.1.2 If the user requires a different mode of operation (i.e. reverse acting, split range) it is necessary to reposition internal electrical switches as indicated below. Though the units are factory calibrated for direct acting it is suggested that the user check the calibration.
- 2.1.3 It is not necessary to remove the cover of the unit for calibration if the direct acting mode is desired.

CAUTION Do not apply electrical signal to unit without appropriate supply pressure. Damage may result.

2.2 Direct Acting Calibration

- 2.2.1 In direct acting operation the unit is calibrated so that minimum input signal corresponds to minimum output pressure and increasing input signal results in increasing output pressure.
- 2.2.2 Apply the minimum input signal of the range being used (e.g. 4mA for a 4-20mA unit) (see figure 6).
- 2.2.3 Observe the output pressure. If necessary, adjust the zero screw until reaching minimum output pressure setting. Turn zero screw clockwise to decrease and counter clockwise to increase.
- 2.2.4 Apply the maximum input signal of the range being used (e.g. 20mA for a 4-20mA unit).
- 2.2.5 Observe the output pressure. If necessary, adjust the span screw until reaching maximum output pressure setting. Turn span screw clockwise to decrease and counter clockwise to increase.
- 2.2.6 After setting the span it will be necessary to recheck the zero. Repeat steps 1-4 until both end points are at required values.

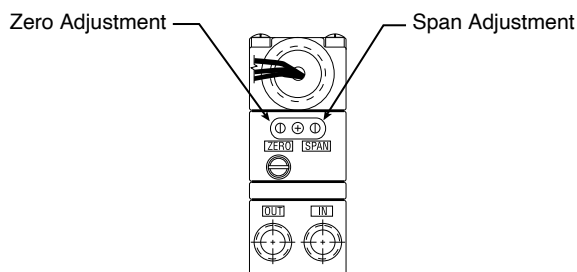

Figure 6 - Zero Adjustment and Span Adjustment

Signal	SWITCH	1	2	3	4	5	6	7	8	9	10	11	12
4-20 mA/0-5V/1-5V	ON			■		■		■		■		■	■
	OFF	■	■		■		■		■		■		■
0-10V/1-9V	ON		■	■		■		■		■		■	■
	OFF	■		■	■		■	■		■	■		■

Figure 7 - Direct Acting - Position of switches for forward acting operation (all output ranges). Standard setting as supplied by factory.

2.3 Reverse Acting Calibration

- 2.3.1 When calibrated to operate in the reverse acting mode the minimum input signal produces the maximum output pressure and increasing the input signal results in decreasing the output pressure. Setting the unit to operate in the reverse acting mode is accomplished by positioning internal electrical switches.

CAUTION Do not reverse the input leads.

- 2.3.2 Disconnect input signal and supply pressure. Take off the top cover by removing the four screws.

CAUTION Avoid touching circuit board, except dip switches. Shorting possible.

- 2.3.3 Position switches as illustrated in figure 8. Replace cover.
 2.3.4 Set the input signal to the minimum valve being used. Turn the zero screw to set the maximum output pressure.
 2.3.5 Set the span by applying the maximum input signal. Turn the span screw to set the minimum output pressure.
 2.3.6 It may be necessary to repeat steps 2.3.4 – 2.3.5 until both end points are at desired values.

SWITCH	3	4	5	6	7	10
ON		■		■		■
OFF	■		■		■	

Figure 8 - Position of switches for Reverse Acting Operation

Note: Switches not shown match Direct Acting Settings (see figure 7).

2.4 Split Range

- 2.4.1 When calibrated to operate in the split range mode, a full input signal (i.e. 4-20mA) will operate the unit at one half the normal output span (i.e. 3-9 psig, 9-15 psig). Setting the unit to operate in the split range mode is accomplished by positioning internal electrical switches.
 2.4.2 Disconnect input signal and supply pressure. Take off the top cover of the unit by removing the four screws.

CAUTION Avoid touching circuit board, except dip switches. Shorting possible.

- 2.4.3 Position switches as illustrated in figure 9. Replace cover
 2.4.4 After setting switches, refer to the appropriate calibration procedure (Direct Acting or Reverse Acting) to get to desired output range (i.e. 3-9 psig, 9-15 psig).

Figure 9 - Position of switches for Split Range Operation

SWITCH	1	2
ON	■	■
OFF		

4-20 mA/0-10V/1-9V

SWITCH	1	2
ON		■
OFF	■	

0-5V/1-5V

Note: Switches not shown match Direct Acting Settings (see figure 7).

2.5 Field Selectable Calibration (Optional)

NOTE Units with field selectable option can not be split ranged.

CAUTION Do not touch any components on circuit board except dip switches.

- 2.5.1 Unit is shipped calibrated and labeled as ordered. Changing the unit to operate in a different range is accomplished by positioning internal dip switches.
- 2.5.2 Disconnect input signal and supply pressure. Take off the top cover of the unit by removing the four screws.
- 2.5.3 Position switches as illustrated in Figure 10 to reach desired output range. Replace cover.
- 2.5.4 Replace both covers by reversing procedure of step 2.5.2.
- 2.5.5 After replacing cover, refer to the appropriate calibration procedure (Direct Acting or Reverse Acting) to get to desired output range (i.e. 3-15 psig, 3-27 psig or 6-30 psig).

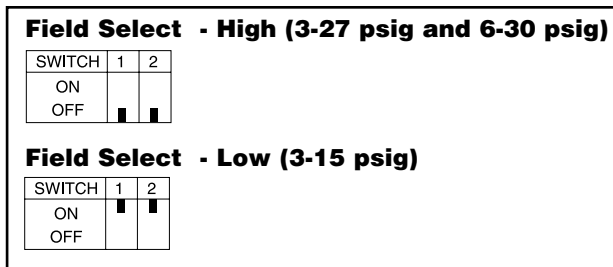

Figure 10 Field Select Switch Setting

Note: Switches not shown match Direct Acting Settings (see figure 7).

NOTE Under normal circumstances, no maintenance should be required.

3.1 Cleaning

- 3.1.1 If clean, dry air is not used the orifice can become blocked. To clear, first turn off supply air, then remove the screw located under the zero adjustment. The orifice is located between the two black o-rings. You may need a magnifying glass to see it. Unplug the orifice by running a wire that has a smaller diameter than 0.012" (0.30mm) through it.
- 3.1.2 Used compressed air to blow out any loose particles inside the orifice screw assembly.

3.2 Precautions

- 3.2.1 Do not apply electrical input for extended periods without air pressure being present.
- 3.2.2 The bonnet should be removed only if a different operation mode is desired which requires a change in circuit board switch settings. In this case, precautions are necessary.
- 3.2.3 Never handle circuit board unless properly grounded to prevent ESD (Electro-static Discharge).
- 3.2.4 If ESD grounding equipment is not available, hold the T900 by its castings and adjust switches using a non-conductive device such as a pencil or a small rubber handled screwdriver.
- 3.2.5 Never remove the circuit board for any reason. This will shift other components and possibly damage the pressure sensor, both cases resulting in malfunction.
- 3.2.6 Use caution when replacing bonnet. If any resistance is felt, remove bonnet and determine the interference. Typically it will be the strain relief grommet on the wires. The grommet should be oriented so it sits beside the switches.
- 3.2.7 Clean, dry air should be used with the T900. Foreign matter in the supply line can clog the orifice openings. (.013" for a 3-15 psig unit, smaller for higher range units.) Foreign matter can also collect on the actuator causing erratic operation. Moisture in the supply line can damage circuit board components.
- 3.2.8 The electrical specifications as outlined in the T900 instructions must be complied with. If more than one T900 mA unit is driven by the same PLC, there must be a minimum of 9.5 v DC available to each unit. For a T900 voltage unit, there must be a constant supply voltage of 7-30 v DC applied to the red wire. The variable control voltage is applied to the orange wire.
- 3.2.9 If difficulty is experienced during calibration or if turning the zero or span screw has no effect on the unit, a resetting technique can be taken. Turn both the zero and span screw a minimum of 30 revolutions in one direction. Then turn both screws exactly 15 revolutions in the opposite direction. This procedure will put the potentiometers at their midpoint of effective adjustability. Next, calibrate to desired settings starting with the zero screw.
- 3.2.10 Reverse Acting Mode: For reverse acting units, the zero adjustment refers to the minimum electrical signal and maximum output pressure. The span refers to the maximum signal and the minimum output pressure. For calibration in reverse mode the resetting technique can be taken if necessary and calibration should always begin with the zero screw.

4. TROUBLESHOOTING

PROBLEM	CHECK	SOLUTION
Sluggish performance or reduced range	Blocked orifice Supply pressure	Clean orifice (3.1) Increase supply pressure (see specs)
Leakage	Connections	Check seal at port
Low or improper span	Supply pressure Connections	Increase supply pressure (see specs) Check seal at port
Erratic operation	Moisture in air supply Loose wires or connections Dip switch settings	Use clean, dry air (see specs) Check wiring (1.5) Reset dip switches (2.2/2.3/2.4)

NOTE If problems are not solved by troubleshooting procedures, contact a factory applications engineer at 603-886-9400 for further assistance.

5. WARNING

FAILURE MODES: This device must not be used for protecting final control elements connected to the output port from the effect of pressure present at the supply port. If devices connected to the output port have a pressure rating less than the pressure present at the supply port, then pressure relieving or pressure limiting devices must be employed to protect the devices from over pressurization, possibly causing physical damage, personal injury and/or property damage.

6. WARRANTY & DISCLAIMER

ControlAir LLC products are warranted to be free from defects in materials and workmanship for a period of eighteen months from the date of sale, provided said products are used according to ControlAir LLC recommended usages. ControlAir LLC's liability is limited to the repair, purchase price refund, or replacement in kind, at ControlAir LLC's sole option, of any products proved defective. ControlAir LLC reserves the right to discontinue manufacture of any products or change products materials, designs or specifications without notice.

Before using these products with fluids other than air, for non-industrial application, life-support systems, or other applications not within published specifications, consult ControlAir LLC.



8 Columbia Drive
Amherst, NH 03031 USA
603-886-9400
Fax: 603-889-1844
www.controlair.com
sales@controlair.com

