



# Type 855BP

## Miniature Back Pressure Regulator

The Type 855BP Back Pressure Regulator is a compact unit that provides economical, high performance pressure relief with an adjustable set point. It's primary function is to provide protection against over pressurization in the downstream portion of a pneumatic system. This unit is capable of relief flows up to 35 SCFM. The highly sensitive diaphragm-operated design delivers accurate and repeatable downstream pressure relief.

### Features

- Easy and Accurate Adjustment
- Push-Pull Locking Knob
- 5 Adjustment Ranges (0-5, 0-15, 0-30, 0-60, 0-100 psig)
- 1/4" NPT Porting
- Compact and Lightweight
- Low Cost

#### Relief Capacity Example:

A Type 855BP 1/4NPT regulator is set to start relieving at 20 psig. As system pressure exceeds the setpoint, it will start relieving. If the pressure were to reach 30 psig, the 855BP would flow at a rate of 9 scfm.

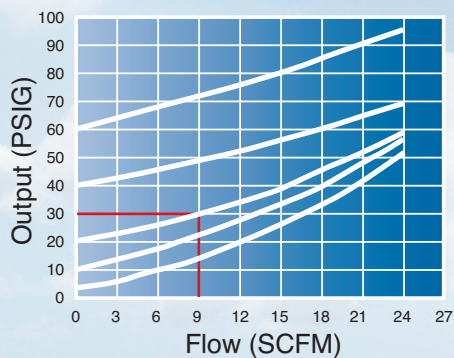

# Type 855BP Miniature Back Pressure Regulator

## Specifications

<b>Relief Capacity</b>	35 scfm (990 NI/min) depending on set point pressure and port size
<b>Maximum System Pressure</b>	250 psig (17.2 BAR)
<b>Operating Temperature</b>	0°F to 150°F (-18°C to 60°C)
<b>Porting</b>	Inlet and outlet-1/4" NPT, Gauge (2) - 1/8" NPT
<b>Output Ranges</b>	0-5 psig (0-0.4 BAR), 0-15 psig (0-1.0 BAR), 0-30 psig (0-2.1 BAR), 0-60 psig (0-4.1 BAR), 0-100 psig (0-6.9 BAR)
<b>Materials</b>	Spring/Adjusting Screw: Zinc-plated Steel Body: Epoxy Coated Zinc Bonnet, Piston: Acetal Diaphragm, O-ring: Nitrile Valve Seat: Aluminum
<b>Weight</b>	4.0 oz. (113 g)

## Dimensional Drawings

### Optional Mounting Bracket P/N 446-707-100

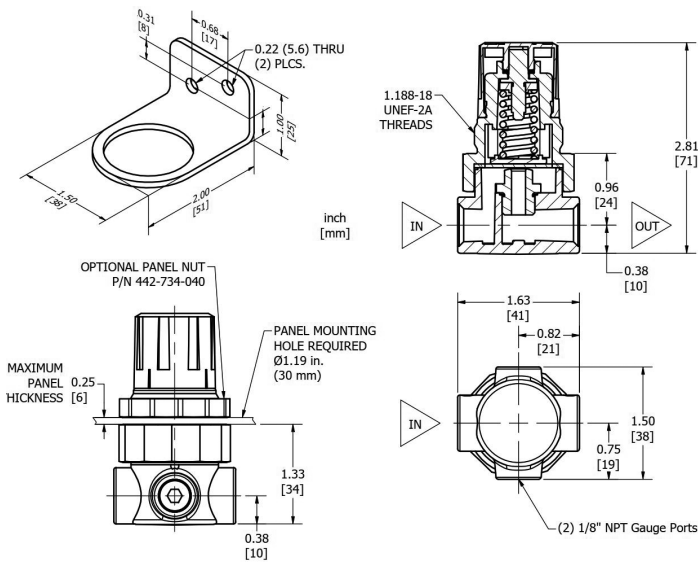

## Ordering Use this coding system to order

**Model**  
**855**

**Port Size**  
**B 1/4" NPT**



	Output psig	BAR
<b>E</b>	0-5	0-0.4
<b>A</b>	0-15	0-1.0
<b>B</b>	0-30	0-2.1
<b>C</b>	0-60	0-4.1
<b>D</b>	0-100	0-6.9

## Accessories

Mounting Bracket:	P/N 446-707-100	Panel Nut:	P/N 442-734-040
Gauge: 0-15 psi	P/N 446-725-005	Gauge: 0-30 psi	P/N 446-725-006
Gauge: 0-60 psi	P/N 446-725-007	Gauge: 0-160 psi	P/N 446-725-008

**Warranty** ControlAir LLC products are warranted to be free from defects in materials and workmanship for a period of eighteen months from the date of sale, provided said products are used according to ControlAir LLC recommended usages. ControlAir LLC's liability is limited to the repair, purchase price refund, or replacement in kind, at ControlAir LLC's sole option, of any products proved defective. ControlAir LLC reserves the right to discontinue manufacture of any products or change products materials, designs or specifications without notice. Note: ControlAir does not assume responsibility for the selection, use, or maintenance of any product. Responsibility for the proper selection, use, and maintenance of any ControlAir product remains solely with the purchaser and end user. Drawing downloads available at [www.controlair.com](http://www.controlair.com)



8 Columbia Drive / Amherst, NH 03031 USA / [www.controlair.com](http://www.controlair.com) / [sales@controlair.com](mailto:sales@controlair.com) / 603-886-9400 / FAX 603-889-1844

An ISO 9001:2015 Registered Company

P/N 441-625-081 8/25/22