



Installation, Operation and Maintenance Instructions

TYPE 7000 Precision Air Pressure Regulator

The Type 7000 is designed to provide high flow capacity while maintaining high accuracy, low droop and precise adjustment. Multiple port size options and rugged construction make the Type 7000 regulator suitable to be used in a wide range of pneumatic control systems.

The Type 7000 utilizes an isolated control chamber to minimize output variation and vibration/honking during flow conditions. An integral aspirator tube helps maintain downstream pressure by compensating for pressure droop during flow conditions. The balanced supply valve virtually eliminates changes due to supply pressure variation.

1. SPECIFICATIONS

Functional Specifications

Output Ranges psi (bar)	0-2 (0-0.15), 0-10 (0-0.69), 0-30 (0-2.0), 0-60 (0-4.0), 0-100 (0-6.89), 0-150 (0-10), 0-200 (0-13.8)	
Supply Pressure	250 psig (17.0 bar) maximum	
Maximum Flow Coefficients (Cv)	Port	Forward
	3/4"	5.0
	1/2"	4.3
	1/4"	2.0
Exhaust Capacity 5 psig (0.35 bar) above 20 psig (1.38 bar) setpoint	30 scfm (849 NL/min)	
Sensitivity	Less than 1/2" water	
Supply Pressure Effect	0.3 psig (0.02 bar) for a 100 psig (6.89 bar) change	
Temperature Limits	-40 to 200 ^o F (-40 to 93 ^o C)	

Physical Specifications

MATERIALS	
Housing:	Aluminum
Bolting:	Zinc Plated Steel
Other Trim:	Aluminum
Internal Components:	Aluminum, Stainless Steel, Brass
Elastomers:	Nitrile
Knob:	Phenolic plastic
Weight	2.5 lbs (1.13 kg)
Supply / Output Ports	1/4", 1/2", or 3/4" NPT
Exhaust Ports	Ø 7/16" or 1/4" NPT option
Gauge Ports (2)	1/4" NPT

2. DIMENSIONAL DRAWING

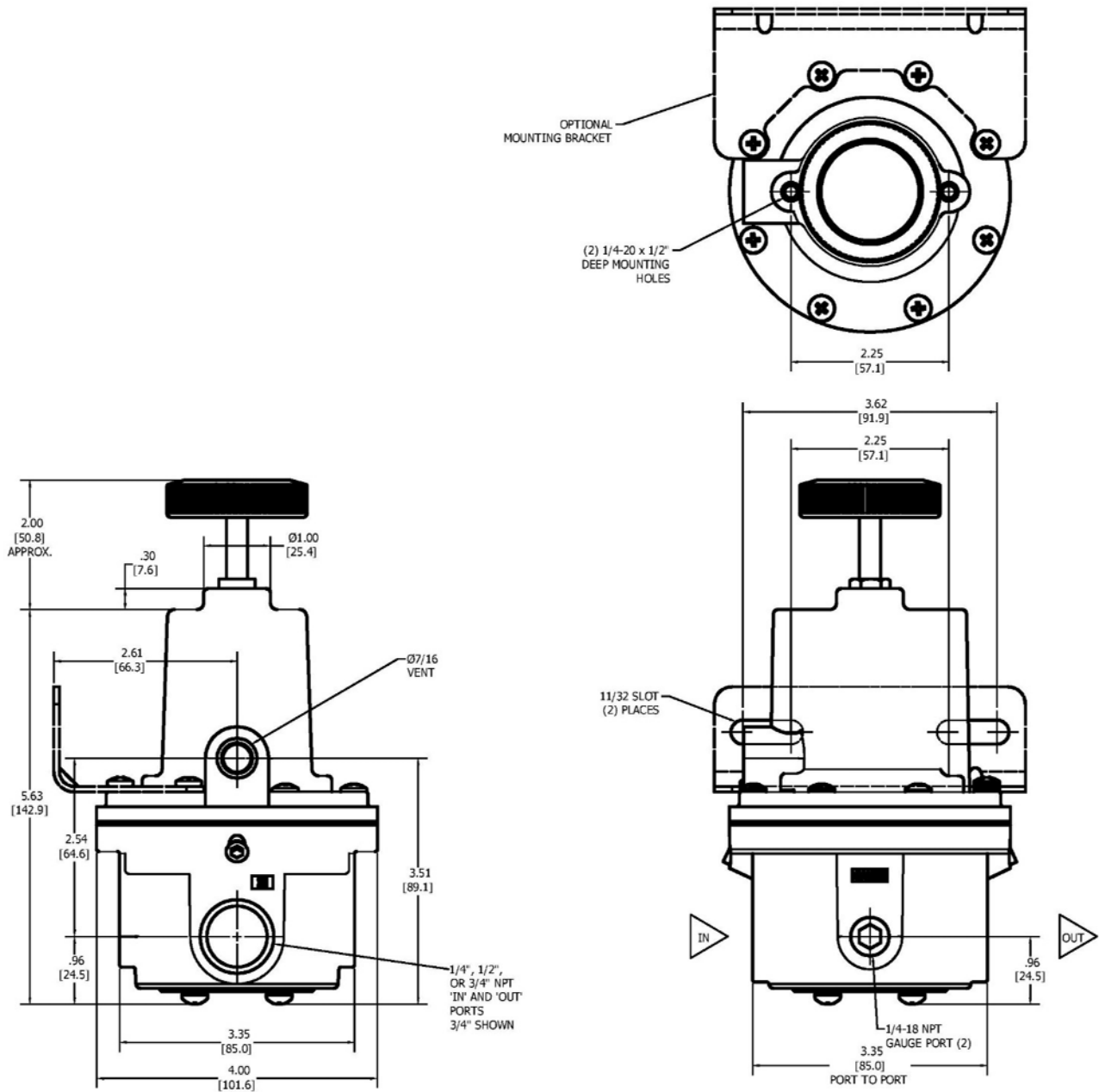

(Drawing downloads available at <http://www.controlair.com>)

3. INSTALLATION



WARNING: Only qualified personnel should install or service a regulator. Regulators should be installed, operated, and maintained in accordance with international and applicable codes and regulations, and ControlAir instructions. If the regulator vents fluid or a leak develops in the system, it indicates that service is required. Failure to take the regulator out of service immediately may create a hazardous condition. Personal injury, equipment damage, or leakage due to escaping fluid or bursting of pressure-containing parts may result if this regulator is over pressured or is installed where service conditions could exceed the limits given in the Specifications section, or where conditions exceed any rating of the adjacent piping or piping connections. To avoid such injury or damage, provide pressure-relieving or pressure-limiting devices (as required by the appropriate code, regulation, or standard) to prevent service conditions from exceeding limits. Additionally, physical damage to the regulator could result in personal injury and property damage due to escaping fluid. To avoid such injury and damage, install the regulator in a safe location.

3.1 Pre-Installation Requirements

- 3.1.1 The Type 7000 requires a source of clean, oil-free dry instrument grade air filtered to 40 microns.
- 3.1.2 Air should be free of all contaminants and hazardous gases, flammable or toxic.
- 3.1.3 Clean all pipelines of dirt and scale prior to installation.

NOTE

Failures attributable to instrument air supply contamination are not covered by the warranty.

CAUTION

This instrument vents to atmosphere. The use of supply gas other than air can create a hazardous environment.

- 3.1.4 Apply a minimum amount of pipe compound to the male threads of the fitting only. Do not use thread sealant tape on pipe fittings as it tends to contaminate the valve causing the regulator to malfunction.

3.2 Installation

- 3.2.1 Install the regulator so that direction of flow is from Inlet to Outlet as labeled “IN” and “OUT” marked on the body. Inlet and outlet porting is 1/4", 1/2" or 3/4" NPT. Tighten all connections securely.
- 3.2.2 Regulator can be mounted in any position and is typically pipe-mounted between the pneumatic supply source and the actuator.

NOTE

Avoid undersized fittings that will limit flow through the regulator and cause pressure drop downstream.

NOTE

The use of a filter regulator to remove dirt and liquid in the air line ahead of the regulator is recommended for best performance.

NOTE

If an air lubricator is used, it should be located downstream beyond the regulator in order to avoid interference with the regulator performance.

- 3.2.3 Ensure that piping to and from the regulator is of proper size to meet the capacity demands of the system.

4. OPERATION

4.1 The Type 7000 is a high flow capacity regulator that provides a uniform output pressure independent of supply pressure variations. Before putting the regulator into service for the first time, relieve pressure on the range spring by turning the knob counterclockwise. To operate, turn the pressure adjusting knob slowly in a clockwise direction until required downstream pressure is obtained. Turned in this direction, the range spring compresses causing increased output pressure.

5. MAINTENANCE AND REPAIRS

NOTE

Under normal circumstances, no maintenance should be required.

5.1 Repairs

- 5.1.1 In the event of unit failure, the Type 7000 can be returned to the factory through point of purchase for warranty repair if the warranty period has not expired.
- 5.1.2 All units returned for repair must be authorized prior to receipt at the factory. Contact a representative at the point of purchase to receive a Return Authorization Number
- 5.1.3 Repair kit for the Type 7000 is available. Repair Kit includes: * Items
Contact factory to order.

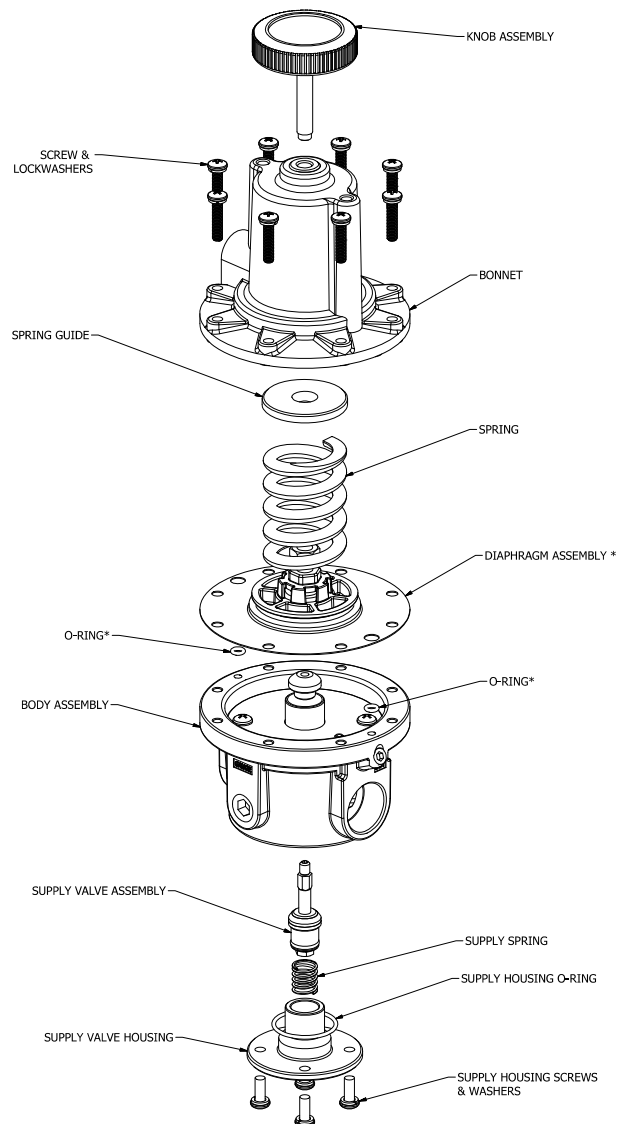

6. WARRANTY & DISCLAIMER

ControlAir LLC products are warranted to be free from defects in materials and workmanship for a period of eighteen months from the date of sale, provided said products are used according to ControlAir LLC recommended usages. ControlAir LLC's liability is limited to the repair, purchase price refund, or replacement in kind, at ControlAir LLC's sole option, of any products proved defective. ControlAir LLC reserves the right to discontinue manufacture of any products or change products materials, designs or specifications without notice. Note: ControlAir does not assume responsibility for the selection, use, or maintenance of any product. Responsibility for the proper selection, use, and maintenance of any ControlAir product remains solely with the purchaser and end user.

WARNING

These products are intended for use in industrial compressed-air systems only. Do not use these products where pressures and temperatures can exceed those listed under Specification