



Type 480V

Precision Vacuum Regulator

The Type 480V vacuum regulator provides precise control up to full vacuum. The push type locking knob provides smooth adjustment. The standard bracket and integral panel nut allows for versatile installation options.

Features

- **Compact Size and low weight**
Allows for in-line pipe mounting
- **Soft valve design**
Provides tight shut off and eliminates leakage in steady state operation.
- **Versatility**
Full vacuum control
- **Easy installation**
Multiple mounting options

Specifications

Regulating Range	0 to 30 in.Hg (-100 to -1.3 kPa)
Atmospheric Intake	0.04 SCFM (1.1 NI/min)
Sensitivity	0.5 in w.c. (0.13 kPa)
Ambient Temperature	32° to 140°F (0° to 60°C)
Weight	0.93 lbs (0.42 kg)
Port size (In and Out)	1/4" BSPT (Rc 1/4)
Port size (Gauge)	1/8 BSPT (Rc1/8)
Flow rate (max.)	100 SCFH (47 NI/min)



Type 480V: Regulated Pressure vs. Flow

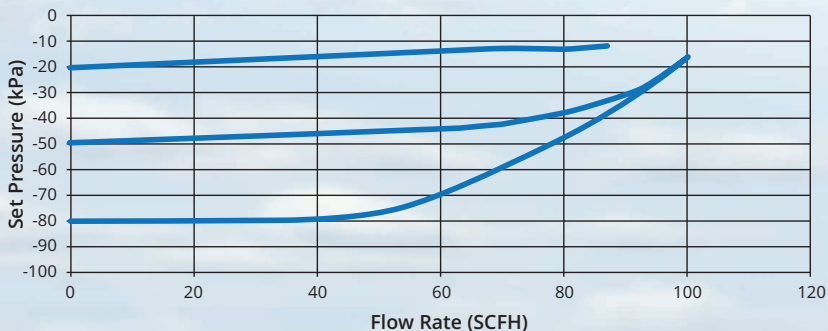

Type 480V Precision Vacuum Regulator

Dimensions

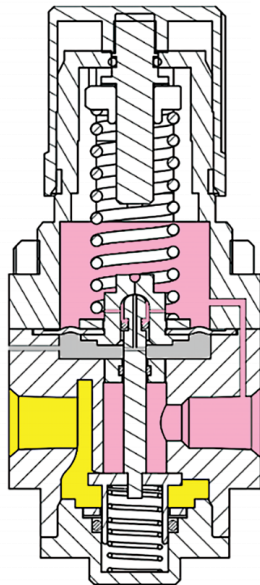
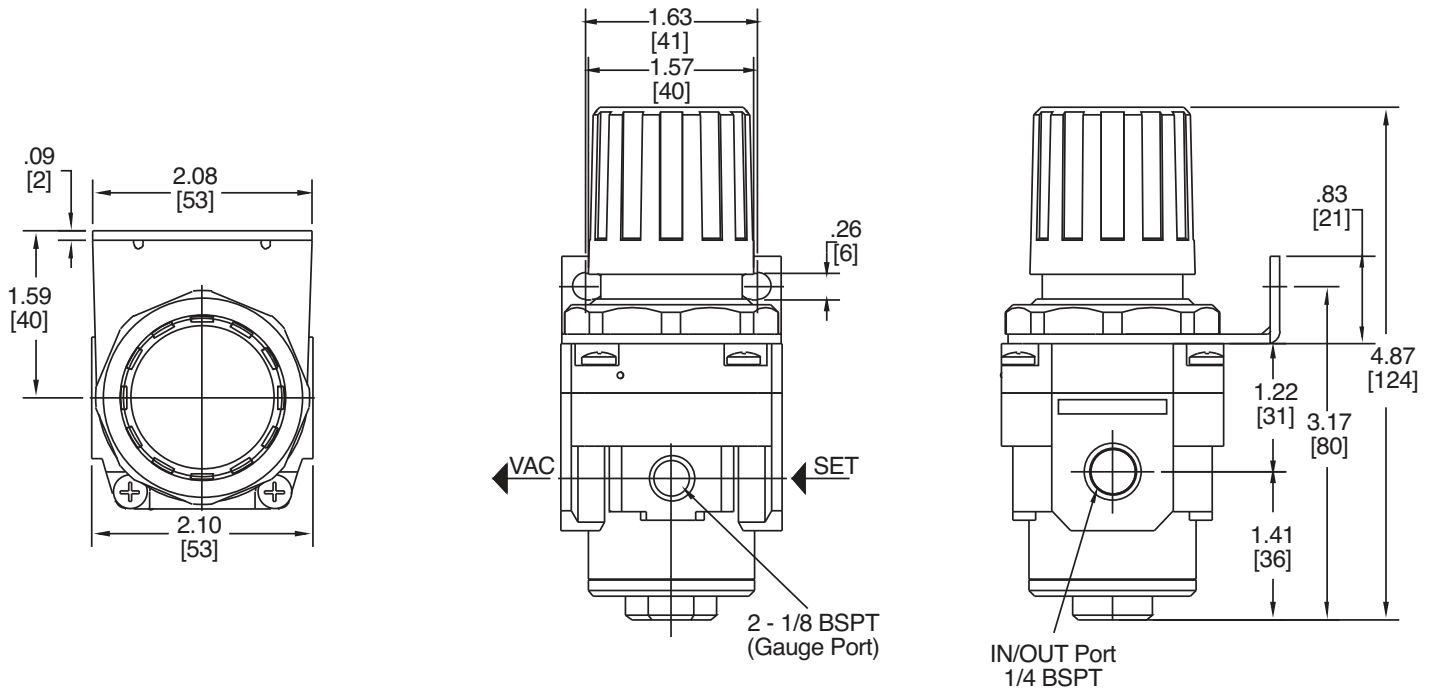

- Full Vacuum
- Regulated Vacuum
- Atmosphere

Ordering

Type	Port Size (BSPT)	Control Range	
		(in.Hg)	(kPa)
480V-BAU	1/4"	0-30	-100 to -1.3

Accessories

G - Pressure Gauge: 1.5" face, back mounted
0 to 30 in. Hg.
P/N 445-725-038

Warranty ControlAir LLC products are warranted to be free from defects in materials and workmanship for a period of eighteen months from the date of sale, provided said products are used according to ControlAir LLC recommended usages. ControlAir LLC's liability is limited to the repair, purchase price refund, or replacement in kind, at ControlAir LLC's sole option, of any products proved defective. ControlAir LLC reserves the right to discontinue manufacture of any products or change products materials, designs or specifications without notice. Note: ControlAir does not assume responsibility for the selection, use, or maintenance of any product. Responsibility for the proper selection, use, and maintenance of any ControlAir product remains solely with the purchaser and end user. Drawing downloads available at www.controlair.com



8 Columbia Drive / Amherst, NH 03031 USA / www.controlair.com / sales@controlair.com / 603-886-9400 / FAX 603-889-1844

An ISO 9001:2015 Registered Company

P/N 441-625-072 11/15/24