



# Installation, Operation and Maintenance Instructions

## Type-330 Filter Regulator Type-335 NACE Filter Regulator Type-340 Regulator Type-345 Filter

### INTRODUCTION

The Type-330/335/340/345 Instrument Air Filter Regulators, Air Regulator & Filter Series are designed for air or gas service. Maximum allowable inlet pressure is 250 psi (17 BAR). Operating temperatures are 0 to 160°F (-62° to 194°F for Low Temperature Option). The Type-330/335/340 has low capacity internal relief which provides very limited down stream over pressure protection. Note: Non-relieving version does not provide internal relief. To avoid exceeding outlet pressure limits in service, a pressure-relieving or pressure-limiting device should be provided.

### SPECIFICATIONS

	TYPE-330		TYPE-335	TYPE-340		TYPE-345	
<b>In/Out Port Size</b> (Gauge Ports 1/4" NPT)	1/4" NPT	1/2" NPT	1/4" NPT	1/4" NPT	1/2" NPT	1/4" NPT	1/2" NPT
<b>Output Ranges</b>	0-30 psig (0-2 bar), 0-60 psig (0-4 bar), 0-120 psig (0-8 bar)		0-30 psig (0-2 bar), 0-60 psig (0-4 bar), 0-100 psig (0-7 bar)	0-30 psig (0-2 BAR), 0-60 psig (0-4 BAR), 0-120 psig (0-8 bar)		N/A	
<b>Maximum Supply Pressure</b>	Manual Drain: 250 psig (17 bar) Auto Drain: 150 psig (10 bar)		250 psig (17 bar)	250 psig (17 bar)		Manual Drain: 250 psig (17 bar) Auto Drain: 150 psig (10 bar)	
<b>Mounting</b>	Pipe, bracket or through body direct						
<b>Filter</b>	40 micron (optional 5 micron)			None		40 micron (optional 5 micron)	
<b>Cv Values</b>	0.5 at 150 psig supply and 80 psig setpoint	2.5 at 150 psig supply and 80 psig setpoint	0.5 at 150 psig supply and 80 psig setpoint	0.5 at 150 psig supply and 80 psig setpoint	2.5 at 150 psig supply and 80 psig setpoint	0.5 at 150 psig supply and 80 psig setpoint	2.5 at 150 psig supply and 80 psig setpoint
<b>Exhaust Capacity</b>	0.1 scfm (3 NI/min) with downstream pressure 5 psig (0.3 bar) above set point					N/A	
<b>Sensitivity</b>	1" of water					N/A	
<b>Air Consumption</b>	Less than 5 scfh (2.5 NI/min)					N/A	
<b>Effect of Supply Pressure Variation</b>	Less than 0.25 psig (0.017 bar) for 25 psig (1.7 bar) change	Less than 0.5 psig (0.035 bar) for 25 psig (1.7 bar) change	Less than 0.25 psig (0.017 bar) for 25 psig (1.7 bar) change	Less than 0.25 psig (0.017 bar) for 25 psig (1.7 bar) change	Less than 0.5 psig (0.035 bar) for 25 psig (1.7 bar) change	N/A	
<b>Temperature Limits</b>	Manual drain: 0° to 160° F (-18° to 71° C) Auto drain: 32° to 160° F (0° to 71° C) Low Temp. Option: -62° to 194° F (-52° to 90° C)		-20° to 180° F (-29° to 82° C)	0° to 160° F (-18° to 71° C)		0° to 160° F (-18° to 71° C) 32° to 160° F (0° to 71° C) -62° to 194° F (-52° to 90° C)	
<b>Weight</b>	Manual drain: 1.2 lb (0.54 kg) Auto drain: 1.42 lb (0.64kg)	1.71 lb (0.78kg) 1.65 lb (0.75 kg)	1.71 lb (0.78kg) N/A	1.15 lb (0.52 kg) N/A	1.38 lb (.63 kg) N/A	1.0 lb (0.45 kg) 1.2 lb (0.54 kg)	1.5 lb (0.68 kg) 1.5 lb (0.68 kg)
<b>Operating Media</b>	Air, Inert Gas & Sweet Natural Gas		Air, Inert Gas & Sweet or Sour Natural Gas	Air, Inert Gas & Sweet Natural Gas		Air, Inert Gas & Sweet Natural Gas	

### MATERIALS

<b>Body</b>	Diecast Aluminum Alloy, Irridite and Baked Epoxy Finish						
<b>Filter</b>	Polyethylene		Polyethylene	None		Polyethylene	
<b>Diaphragm</b>	Nitrile Elastomer and Nylon Fabric Low Temp. Option: Silicone and Nitrile		Viton	Nitrile Elastomer and Nylon Fabric Low Temp. Option: Silicone and Nitrile		N/A	
<b>Valve Seat</b>	Nitrile Elastomer		Nitrile Elastomer	Nitrile Elastomer			
<b>Additional Materials</b>	Brass, Zinc Plated Steel, Acetal			Brass, Zinc Plated Steel, Acetal			

### INSTALLATION

1. Install the regulator/filter as close as possible to the instrument or tool it is to service.
2. Clean all pipelines to remove dirt and scale prior to installation.
3. Install the regulator/filter so that the direction of flow is from the "IN" to "OUT" connection as marked on the body of the regulator/filter.
4. For best drainage, orient the drain valve so that it is at the lowest point on the drip well housing. Positioning of the drain valve may be improved by rotating the drip well with respect to the body.
5. The exhaust port should be kept free and unplugged. Rotating the bonnet relative to the body may change the vent hole orientation.

6. Exhaust may be remotely vented by installing tubing to the 1/4" NPT port. (E Option)
7. Apply pipe compound or sealing tape to the main pipe threads prior to installing regulator/filter. Use caution to prevent the sealant from getting inside the regulator/filter.



**WARNING:** Only qualified personnel should install or service a regulator. Regulators should be installed, operated, and maintained in accordance with international and applicable codes and regulations, and ControlAir instructions. If the regulator vents fluid or a leak develops in the system, it indicates that service is required. Failure to take the regulator out of service immediately may create a hazardous condition. Personal injury, equipment damage, or leakage due to escaping fluid or bursting of pressure-containing parts may result if this regulator is over pressured or is installed where service conditions could exceed the limits given in the Specifications section, or where conditions exceed any rating of the adjacent piping or piping connections. To avoid such injury or damage, provide pressure-relieving or pressure-limiting devices (as required by the appropriate code, regulation, or standard) to prevent service conditions from exceeding limits. Additionally, physical damage to the regulator could result in personal injury and property damage due to escaping fluid. To avoid such injury and damage, install the regulator in a safe location. The internal relief valve in the Type-330 regulators does not provide full overpressure protection. The internal relief valve is designed for minor seat leakage only.

## OPERATION

1. Prior to turning on supply air, back off adjusting screw until there is no compression of the range spring.
2. After applying the air supply, outlet pressure will be increased by rotating the adjustment screw clockwise. Pressure can be decreased by turning counter clockwise.
3. Tighten locknut to maintain desired pressure setting.



**WARNING:** To avoid personal injury resulting from sudden release of pressure, isolate the regulator from all pressure before attempting disassembly.

## MAINTENANCE

1. To remove condensate, from the Type-330/335/345, slowly open drain valve by turning clockwise and bleed accumulated liquid.



**WARNING:** To avoid personal injury, property damage, or equipment damage caused by sudden release of pressure or explosion of accumulated gas, do not attempt any maintenance or disassembly without first isolating the regulator from system pressure and relieving all internal pressure from the regulator.

2. To clean filter element (Type-330/335/345)
  - a) Shut off supply pressure and relieve all internal pressure.
  - b) Drain condensate from drip well.
  - c) Remove four corner bolts from bottom of unit and remove drip well housing.
  - d) Remove filter retaining screw.
  - e) Remove filter retainer, filter o-ring seals and filter.
  - f) Clean parts and reassemble in reverse order.
3. To clean/replace pintle assembly
  - a) Follow steps (a) through (d) above.
  - b) Unscrew collar and remove. (1/2" NPT only)
  - c) Remove pintle spring. The Type-340 does not contain a filter or collar. The pintle and pintle spring will be accessible upon removal of base.
  - d) Clean or replace parts as required. Apply a high quality lubricant to all cleaned or replaced o-ring seals.
  - e) Reassemble in reverse order.
4. To clean/replace diaphragm assembly
  - a) Back out the adjusting screw until the spring is no longer compressed.
  - b) Remove the four bonnet screws and separate the bonnet from the body of the regulator. Remove the spring guide and spring.
  - c) Remove the diaphragm assembly, clean or replace it as necessary and reassemble in reverse order. After placing the diaphragm assembly on the body, push down the assembly to make sure that the pintle is seated properly and strokes smoothly.
5. Repair kits/replacement parts
  - a) Repair kits include all parts marked with an asterisk (\*).
  - b) Order kit as described in exploded view below
  - c) Shut off supply air. Back out adjusting screw
  - d) Remove four corner bolts from bottom of the unit and four screws on top and remove all parts.
  - e) Replace all parts that show excessive wear. Apply a high quality lubricant to all cleaned or replaced o-ring seals.
  - f) Clean all parts and replace in reverse order



**WARNING:** The materials of the Type-330/335/340/345 are compatible with natural gas. The user should be warned, however, that the Type-330/335/340 regulator/filter may vent some gas to the atmosphere. In hazardous or flammable service, vented gas may accumulate and cause personal injury, death, or property damage due to fire or explosion. If regulator is used in a hazardous gas service area, the regulator must be vented to a remote, safe location away from air intakes or any other hazardous area. The vent line or stack opening must be protected against condensation or clogging. Do not use these products where pressure and temperatures can exceed those listed under specifications.

**REPAIR KITS**

<u>Model</u>	<u>Porting</u>	<u>Description</u>	<u>Part Number</u>
Type 330	1/4" NPT	Relieving	449-871-100
Type 330	1/4" NPT	Non-Relieving	449-871-101
Type 330	1/2" NPT	Relieving	449-871-113
Type 330	1/2" NPT	Non-Relieving	449-871-114
Type 330	1/4" NPT	Relieving-5 micron	449-871-139
Type 330	1/2" NPT	Relieving-5 micron	449-871-140

<u>Model</u>	<u>Porting</u>	<u>Description</u>	<u>Part Number</u>
Type 340	1/4" NPT	Relieving	449-871-115
Type 340	1/4" NPT	Non-Relieving	449-871-116
Type 340	1/2" NPT	Relieving	449-871-117
Type 340	1/2" NPT	Non-Relieving	449-871-118

**REPLACEMENT FILTERS**

<u>Model</u>	<u>Porting</u>	<u>Description</u>	<u>Part Number</u>
Type 330/335/345	1/4" NPT	40 micron	446-777-001
Type 330/335/345	1/4" NPT	5 micron	446-777-002
Type 330/335/345	1/2" NPT	40 micron	446-777-024
Type 330/335/345	1/2" NPT	5 micron	446-777-025

**Type-330/340/345 1/2" NPT Units**

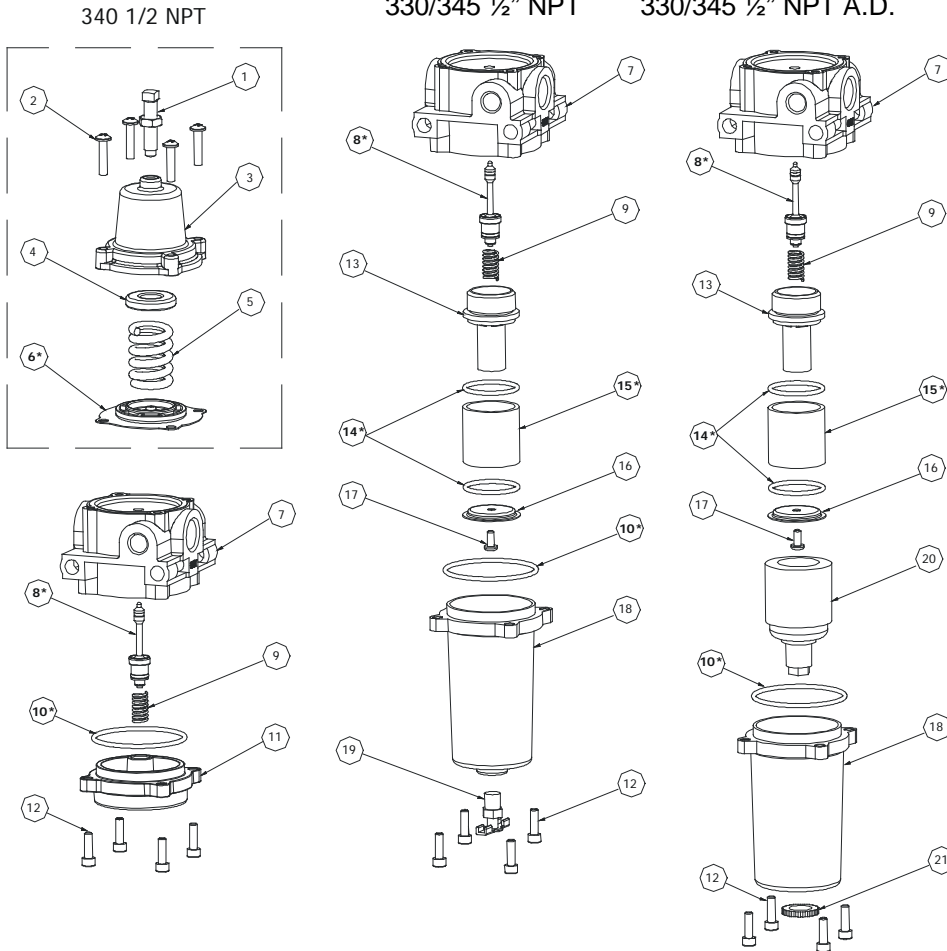

Parts List		
ITEM	QTY	DESCRIPTION
1	1	ADJUSTING SCREW ASSY
2	4	10-24 BUILD SCREW
3	1	BONNET
4	1	SPRING GUIDE
5	1	RANGE SPRING
6	1	DIAPHRAGM ASS'Y
7	1	BODY
8	1	VALVE ASSY
9	1	VALVE SPRING
10	1	O-RING
11	1	BASE ASSY
12	4	10-24 DRIPWELL SCREW
13	1	COLLAR
14	2	SEAL, FILTER
15	1	FILTER
16	1	FILTER RETAINER
17	1	SCREW, RETAINER
18	1	DRIPWELL
19	1	DRAIN VALVE
20	1	AUTODRAIN VALVE
21	1	NUT, AUTODRAIN VALVE

\* INCLUDED IN REPAIR KIT

## Type-330/335/340/345 1/4" NPT Units

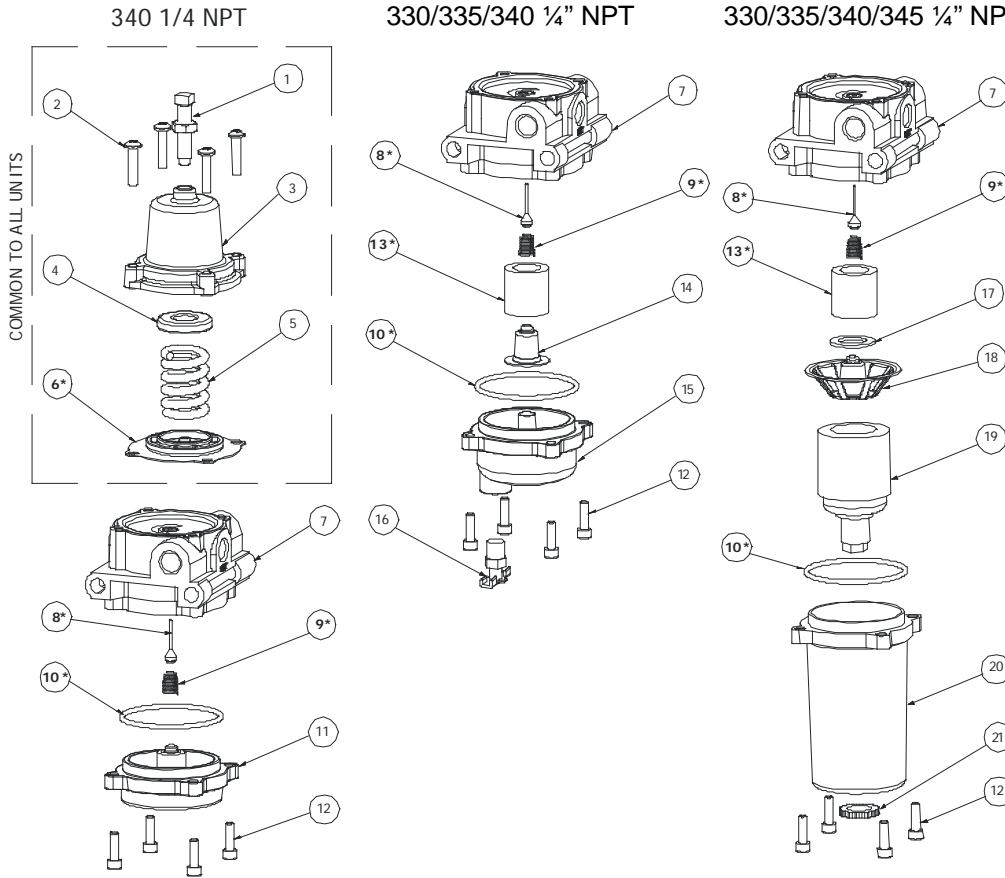

Parts List		
ITEM	QTY	DESCRIPTION
1	1	ADJUSTING SCREW ASS'Y
2	4	10-24 BUILD SCREW
3	1	BONNET
4	1	SPRING GUIDE
5	1	RANGE SPRING
6	1	DIAPHRAGM ASS'Y
7	1	BODY
8	1	PINTLE
9	1	PINTLE SPRING
10	1	O-RING
11	1	BASE ASS'Y
12	4	10-24 DRIPWELL SCREW
13	1	FILTER
14	1	FILTER RETAINER
15	1	DRIPWELL
16	1	DRAIN VALVE
17	1	GASKET
18	1	FILTER RETAINER
19	1	AUTODRAIN VALVE
20	1	DRIPWELL A.D.
21	1	NUT, AUTODRAIN VALVE

\* INCLUDED IN REPAIR KIT

### LIMITED WARRANTY & DISCLAIMER

ControlAir LLC products are warranted to be free from defects in materials and workmanship for a period of eighteen months from the date of manufacture, provided said products are used according to ControlAir LLC recommended usages. ControlAir LLC's liability is limited to repair of, refund of purchase price paid for, or replacement in kind of, at ControlAir LLC's sole option, any products proved defective. ControlAir LLC reserves the right to discontinue manufacture of any product or change product materials, design or specifications without notice. Note: ControlAir does not assume responsibility for the selection, use, or maintenance of any product. Responsibility for the proper selection, use, and maintenance of any ControlAir product remains solely with the purchaser and end user.